

## EverGreen Plus City Water Carbon Solutions

### Featuring Backwashing Granular Activated Carbon Filtration for Chemical, Taste, and Odor Reduction

The **EverGreen Plus City Water Carbon Solutions** are a high-performance carbon filtration systems engineered to **remove chlorine, chloramine, disinfection byproducts, and unpleasant tastes and odors** from municipal water. Using a USA-made Vortech™ tank and customizable control valve, this system ensures **consistent media performance and extended bed life**—all with minimal maintenance and water waste.

During regeneration, the system initiates a **vigorous backwash** to lift and reclassify the carbon media, **removing accumulated particulates and preventing channeling**. This **maintains high adsorption capacity and flow consistency** over time, even in high-usage households or light commercial settings.

Through the use of flexible programming, efficient hydraulics, and media optimized for chlorine and organics, the EverGreen Plus City Water Carbon Solutions reliably delivers clean, fresh water throughout your home or facility with much less waste.

#### Features

- **Proprietary Control Valve** – Fully programmable system cycles and regeneration parameters
- **Backwashing Operation** – Reclassifies carbon media and prevents channeling for longer media life
- **Vortech™ Tank Technology** – Reduces backwash water usage and time by over 30%
- **No Chemical Regeneration** – Simple operation, no salt, no additives
- **Engineered for Residential and Light Commercial City Water Applications** – Configurable to meet varying contaminant loads

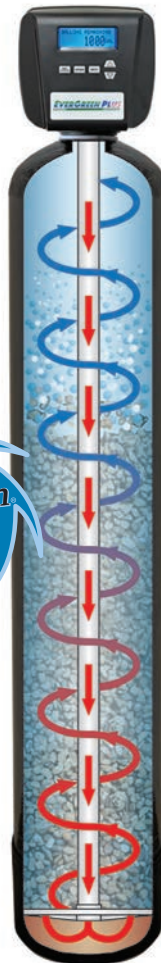

#### Benefits

- ✓ Removes chlorine, chloramine, and chemical odors
- ✓ Improves taste and clarity of water
- ✓ Low-maintenance operation with automatic regeneration
- ✓ Extends life of plumbing fixtures and appliances
- ✓ Sustainable water use – lower drain volumes than traditional filters
- ✓ Easy to install and maintain

#### Applications

- Residential homes on municipal water
- Light commercial facilities (salons, offices, daycare, etc.)
- Ideal for areas with high chlorine or chloramine levels
- Perfect for use before RO or softening systems



## EverGreen Plus City Water Carbon Solutions

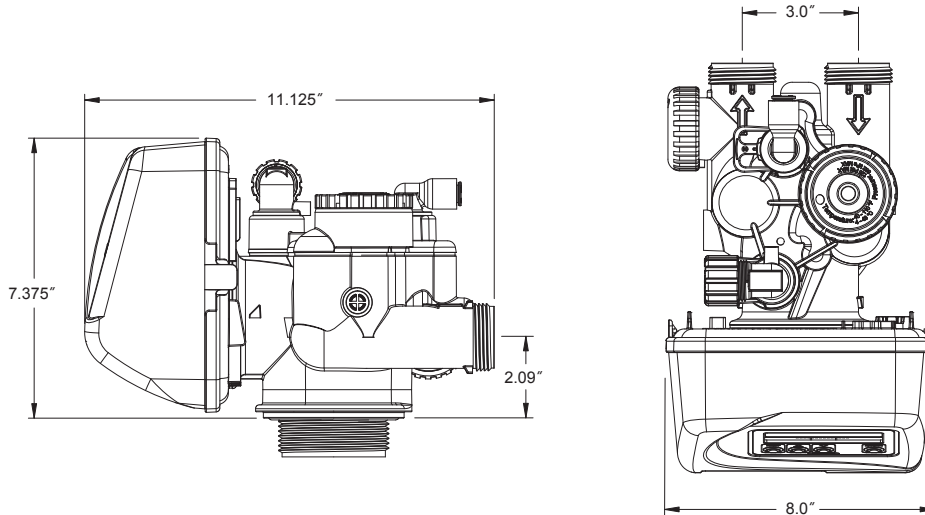

### EverGreen Plus Carbon Filter Models

Model Number	Media Type	Cu Ft	Tank Size	Flow Rate (GPM)	Backwash Rate (GPM)
UFV1054-100-GAC-NAD	GAC Granular Activated Carbon	1.5	10 x 54	8.5	3.0
UFV1252-100-GAC-NAD	GAC Granular Activated Carbon	2.0	12 x 52	10.0	3.5
UFV1354-100-GAC-NAD	GAC Granular Activated Carbon	2.5	13 x 54	12.0	4.5
UFV1465-100-GAC-NAD	GAC Granular Activated Carbon	3.0	14 x 65	14.0	5.0

*All performance data based on standard city water conditions and manufacturer-rated flow/loading guidelines. Performance may vary based on specific water quality and demand.*

### Need Help Selecting a System?

An accurate water analysis is the best first step.

Contact your local **EverGreen Plus Dealer** to ensure the right size and media for your water.